

Service and
Warranty
Information



2005
325i SULEV

The Ultimate
Driving Machine®



Owner/Driver Information:

Name _____

Address _____

Owner/Driver Telephones:

Business _____

Home _____

Model 325i SULEV Year 2005

VIN

--	--	--	--	--	--	--	--	--	--	--	--	--	--	--	--	--	--	--	--

Retail/In-Service Date _____

Trim Code _____ Color Code _____

Production Date _____

License Plate Number _____

BMW Center Telephone Numbers:

Offices _____

Services _____

Table of Contents

Introduction (SULEV (PZEV))	1
Full Maintenance Program	2
Maintenance System	3,4
Quality Certification I	5
Unscheduled Maintenance	5
Engine Oil Service	6
Inspection I	7,8
Inspection II	9
Brake Fluid, Oxygen Sensor, Spark Plug, Automatic Transmission Services	9
Special Maintenance Record	10
Scheduled Maintenance, Oil Service Record	11-13
Emission Control Maintenance Schedule	14
Battery Care	15
Corrosion Protection	15
Body Inspection	16-21
Customer Assistance Information	22
Customer Assistance Notification	23-25
BMW Import Processing Centers	25
Special Programs	25
Roadside Assistance	
– Owner's Eligibility	26
– Getting Started	26
– Calling for Assistance	26
– Dispatch Service	27
– On-Site Assistance	27
– Lock Out	27
– Towing Service	27
– Sign-and-Drive	27
– Trip Interruption Benefits	27
– Car Rental Discounts	28
– Auto Valet Service	28
– Personalized Trip Routing	28
– Exclusions	28
Summary of BMW Limited Warranties	29
New Vehicle Limited Warranty	30,31
Limited Warranty Rust Perforation	32
Federal Emission System Defect Warranty	33,34
Federal Emission Performance Warranty	35,36
California Emission Control Warranty Statement	37
California Emission Control System Limited Warranty	38-40
Notice of Owner/Address Change	41
Tire Warranty Statement	41

Models Covered in this Booklet

325i

325Ci

325Ci convertible

325iT

330i

330Ci

330Ci convertible

SULEV (PZEV):

325i

325Ci

325iT

Introduction (for SULEV (PZEV) only)

Certain 325i models are certified to California's stringent Super Ultra Low Emission Vehicle (SULEV) standards and also qualify as a Partial Zero Emission Vehicle (PZEV) under the California Air Resources Board Zero Emission Vehicle program. In addition to very low tailpipe and zero-evaporative emissions, this PZEV certification includes a unique warranty when the vehicle is registered in California and certain Northeastern states as indicated elsewhere in this booklet.

The emission certification standard can be verified on the Vehicle Emission Control Information label located in the engine compartment. A representative label is shown below, with the SULEV (PZEV) certification indicated by the arrow.

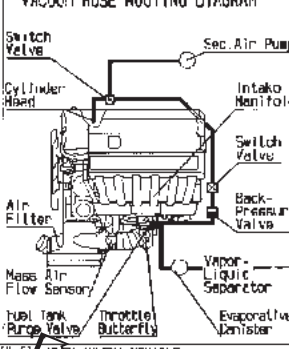
 <p>VEHICLE EMISSION CONTROL INFORMATION Bayerische Motoren Werke AG</p> <p>MODEL: BMW 325i, 325Ci 325i sport wagon TEST GROUP: 4 BMXV02.5M56 EVAPORATIVE EMISSION FAMILY: 48MXR0134M56 ENGINE DISPLACEMENT: 152.5 cu. in / 2494 cu. cm EXHAUST EMISSION CONTROL SYSTEM: 2VU-TWC, 2TWC, 2 A/F-Sensor, 2HO2S, SFI, AIR, DOR-System CERTIFICATION FUEL: CALIFORNIA PHASE II GASOLINE NO ADJUSTMENT NEEDED/OBD II CERTIFIED</p> <p>JE11G25F CATALYST</p> <p><small>THIS VEHICLE CONFORMS TO U.S. EPA TIER2 (BIN 5) NEW SULEV1 VEHICLE REGULATIONS APPLICABLE TO 2005 MODEL YEAR NEW MOTOR VEHICLE AND TO CALIFORNIA REGULATIONS APPLICABLE TO 2005 MODEL YEAR NEW SULEV1 (PZEV) PASSENGER CARS. (X XXX XXX</small></p>	<p>VACUUM HOSE ROUTING DIAGRAM</p> 
--	--

BMW Full Maintenance Programs - 2005 Models

BMW Full Maintenance Programs are a benefit designed to help reduce the cost of scheduled and unscheduled maintenance.

2005 3 Series vehicles (except M3)

purchased from any Authorized BMW center in the United States or Puerto Rico are covered by Full Maintenance for 48 months or 50,000 miles, whichever occurs first. Coverage begins on the date of first retail sale or the date the vehicle is first placed in service as a demonstrator or company vehicle, whichever is earlier.

Any authorized BMW center in the United States or Puerto Rico will perform the scheduled or additional maintenance services on your vehicle at no expense to you. The maintenance schedule intervals are based on normal driving conditions and operation.

Should you request more frequent maintenance service, the cost of these services will not be covered by the Maintenance Program.

Coverage

Full Maintenance covers all factory recommended maintenance, as determined by the service interval indicator. Additional items that need replacement due to normal wear and tear, and that are not covered by the original New Vehicle Limited Warranty - such as brake pads, brake rotors, and wiper blade inserts - are included, provided wear and tear exceeds BMW specifications. Any adjustments required due to normal operating conditions are also included. See pages 6-9 of this booklet for additional information.

Maintenance Intervals

Time intervals should be followed using the maintenance interval as indicated by the BMW Service Indicator lights on the check control panel in the dashboard.

This BMW Service and Warranty Information Booklet should be presented to your BMW center when maintenance is required. Your BMW center will stamp this book documenting the services or maintenance performed.

Exclusions from coverage

- Items reimbursable under your New Vehicle Limited Warranty.
- Gasoline and gasoline additive.
- Windshield washer additive (except when in conjunction with scheduled maintenance).
- Tires, wheel alignment, tire balance and rotation.
- Wear and tear of soft trim items, such as: seats, carpets, moldings, headliner, door panels and all chrome trim.
- Damage detected when performing the rust perforation inspection.
- Damage which results from negligence, improper operation of the vehicle, wear and tear or deterioration due to driving habits or conditions, improper repair, environmental influences, flood, accident or fire damage, road salt corrosion, alteration, installation of non-BMW accessories, or use of improper, poor quality or contaminated fuel.
- Altered or unreadable Vehicle Identification Number (VIN) or odometer irregularities or vehicles where the true mileage cannot be determined.
- Maintenance or repair after the vehicle is deemed a total loss.
- Maintenance or repairs performed by other than an Authorized BMW center within the United States or Puerto Rico.
- Vehicles used in competitive events.
- Oil changes performed outside the recommended maintenance intervals as indicated by the Service Interval Indicator.

Maintenance Upgrade Option

Please contact your authorized BMW center for information regarding an optional 6 year 100,000 mile maintenance upgrade.

Maintenance System

The BMW Maintenance System has been devised with the following objectives: to maximize vehicle safety, reliability, and resale value by minimizing breakdowns resulting from wear, and minimizing cost and inconvenience by computing maintenance intervals based upon the specific manner in which each individual vehicle is driven.

Maintenance intervals on motor vehicles have conventionally been specified based upon accumulated mileage. However, the type of driving conditions has a major influence on routine maintenance requirements; distance traveled is only one of the significant factors. A vehicle driven for 50,000 miles of short trips in the city with numerous cold starts, prolonged periods of idling, stop-and-go driving, and high engine speeds during acceleration requires more frequent maintenance intervals than a vehicle driven for 50,000 miles for long distances at low engine speeds primarily at operating temperature.

The advanced technologies at BMW have led to the development of the unique BMW service interval indicator which computes the actual optimum maintenance requirements based not only upon the accumulated mileage, but taking into account important factors such as engine coolant temperatures, high or low engine speeds, short or long trip driving, and number of vehicle starts. The maintenance interval may therefore be maximized with considerable savings to owners of vehicles subjected to light duty.

The **Service Interval Indicator** consists of a mileage reading, and the inscriptions "OIL SERVICE" and "INSPECTION".

Whenever the ignition is switched on, the display shows the next scheduled type of service and the remaining distance until the service should be performed. The distance is based on your driving style.



If the maintenance interval has been exceeded, a "—" symbol reminds you of the urgent need for servicing. In the interests of road safety and reliability, you should **avoid driving your BMW when the "—" symbol is showing**, and have the essential maintenance work performed without delay.

After each maintenance is performed the service indicator is reset in order to compute the next service interval.

If the Service Interval Indicator displays an illogical reading, or if there is no display, consult a BMW center.

If the speedometer, tachometer or coolant temperature gauge should develop a fault, the service interval indicator will probably cease to operate correctly as well, since it depends on correct speed, distance and temperature readings. The fault must be located and rectified by a BMW center.

A detailed list of all maintenance operations included in each of the elements of the BMW Maintenance System is found on pages 6-9. These elements are as follows:

Quality Certification I will be performed by your selling center and certified on page 5.

The performance of certain subsequent maintenance elements, as required by the BMW New Vehicle Limited Warranty, will be specified at intervals computed by the BMW service interval indicator as follows:

- Oil Service: Engine oil changed with the engine at operating temperature.

Note: change oil at least once a year.

Your BMW is factory-equipped with a newly-developed synthetic engine oil. At the time of the printing of this booklet BMW High-Performance Synthetic 5W-30 Oil (Part Number 07 51 0 017 866) and Mobil 1 5W-30 and 5W-40 oils are strongly recommended and approved by BMW for the 3 Series models covered in this booklet. BMW is evaluating various synthetic oils for inclusion in our list of recommended motor oils.

For the most current list of synthetic oils, please contact your BMW center, or call BMW of North America at 1-800-831-1117. You can also obtain this information from our website, www.bmwusa.com/.

It is recommended to check engine oil level whenever fuel is added to the vehicle.

If you need to add oil between oil changes and are unable to obtain BMW High Performance Synthetic Oil, Mobil 1 or another special oil on the list, use a synthetic oil with an API rating of SJ or higher.

- Inspection I: Major vehicle maintenance as specified in the following pages under Inspection I.
- Inspection II: Additional major vehicle maintenance as specified in the following pages under Inspection II.

The following maintenance elements must be performed at the mileage/time stated (time intervals begin from the vehicle's production date):

- Brake Fluid Service: Change brake fluid every two years.

- Oxygen Sensor Service: The oxygen sensor deteriorates strictly on a mileage basis and must therefore be replaced every 120,000 miles (3 Series with optional Sequential Manual Gearbox (SMG) 100,000 miles), to maximize vehicle fuel economy and minimize exhaust pollution. In the SULEV (PZEV) models, the oxygen sensor must be replaced every 150,000 miles. The replacement of the oxygen sensor is required under the terms of the applicable BMW emission system warranties.
- Spark Plug Service: Replace spark plugs every 100,000 miles. Your BMW is equipped with platinum-tipped spark plugs. These allow a longer service life than conventional spark plugs.
- Automatic Transmission Service: Change ATF every 100,000 miles.

The engine coolant has a lifetime rating and does not need to be changed.

For your convenience, you may also wish to have your BMW center perform any necessary operations to fulfill any state inspection requirements in your area concurrent with the maintenance elements specified above during other repairs.

Make sure that confirmation of maintenance work is always entered in this Service and Warranty Information Booklet. You may need this for any warranty claims that become necessary, and later on as evidence that your car has been given the correct and regular maintenance that justifies its resale or trade-in value.

BMW has applied the most modern technological advances not only to the design and production of your vehicle, but also to computing of the optimum maintenance interval for your type of operations and driving style. Your BMW center has made a substantial investment in unique BMW special service tools to enable his BMW factory trained service technicians to perform quality repairs on your BMW in minimal time. He/she looks forward to serving your every service need and to help maximize your satisfaction with your BMW, its longevity, and resale value.

Quality Certification I
Performed by (selling BMW center/Stamp with Code)
FREE OF CHARGE
Date _____ Mileage _____
Authorized Signature of Service Manager _____

Quality Certification I

For a detailed list of items inspected, refer to the Quality Certification I form provided to the Owner at time of delivery. A copy of the form is on file at the selling BMW center.

Unscheduled Maintenance

Only use fuels advertised to have adequate detergency and low alcohol content. Use of fuels with insufficient detergent and/or excess alcohol can cause driveability problems that necessitate cleaning intake valves and fuel injection valves, and, when applicable, adjusting the engine idle. We suggest having this work performed by your authorized BMW center, perhaps while regular maintenance is performed. Your BMW center can also recommend a gasoline additive that will provide sufficient detergency. While this recommended unscheduled maintenance is not required in order to maintain the emission warranty, cleaning of intake valves or, when applicable, fuel injection valves, or adjustment of engine idle, necessitated by use of inappropriate fuel, is not covered by warranty because no defect in material or workmanship or component failure is involved.

Special Note

Most maintenance items and schedules stated herein reflect the combined recommendations for model year 2005 3 Series BMWs, and are subject to change. The most current maintenance recommendations are available from your authorized BMW center.

Engine Oil Service

Engine Compartment

Engine Compartment	3 Series + Conv.	325i, 325Ci, 325iT SULEV (PZEV)
Change oil and oil filter while engine is at normal operating temperature. We recommend BMW 5W-30 High Performance Synthetic Oil, p/n 07 51 0 017 866.	•	•
Reset service interval indicator.	•	•
Replace microfilter.	•	•
Check overall thickness of front and rear disc brake pads using special tool. If replacement is necessary: Examine brake disc surfaces. Clean brake pad contact points in calipers. Grease wheel centering hubs. Check thickness of parking brake linings only when replacing rear pads.	•	•
Check parking brake actuation. Adjust if necessary.	•	•

Body

Lubricate convertible top sliding linkage covers.	•	
---	---	--

Inspection I

Only those items of inspection work which apply to your vehicle will be performed. This list is subject to amendment.

Undercarriage	3 Series + Conv.	325i, 325Ci, 325iT SULEV (PZEV)
Change oil and oil filter while engine is at normal operating temperature. We recommend BMW 5W-30 High Performance Synthetic Oil, p/n 07 51 0 017 866.	•	•
Check transmission for leaks.	•	•
Check rear axle for leaks.	•	•
Half-shafts: Check for leaks at flexible boots.	•	•
Visually check fuel tank, lines and connections for leaks.	•	•
Check condition, position, and mounting of exhaust system. Examine for leaks.	•	•
Check power steering system for leaks. Check power steering fluid level; add fluid if necessary.	•	•
Check steering for absence of play, condition of suspension track rods, front axle joints, steering linkage and joint disc.	•	•
Check overall thickness of front and rear disc brake pads using special tool. If replacement is necessary: Examine brake disc surfaces. Clean brake pad contact points in calipers. Grease wheel centering hubs. Check thickness of parking brake linings only when replacing rear brake pads.	•	•
Check brake system connections and lines for leaks, damage and incorrect positioning.	•	•
Check parking brake actuation. Adjust if necessary.	•	•
Check all tire pressures (including spare). Correct if necessary. Check condition of tires (outer surface [left/right]), tread wear and pattern; in case of uneven tread wear, readjust wheel alignment if requested (invoice separately).	•	•
Inspect entire body according to terms of rust perforation limited warranty (Must be performed at least every two years).	•	•

Engine Compartment

Read out diagnostic system.	•	•
Check engine cooling system/heater hose connections for leaks. Check coolant level and antifreeze protection level. Add coolant if required.	•	•
Check windshield washer fluid level and antifreeze protection. Fill up and/or correct if required.	•	•
Check air conditioner for operation.	•	•
Replace microfilter. (Note: reduce replacement interval in dusty operating conditions.)	•	•
Reset service interval indicator.	•	•

Inspection I

Body/Electrical

	3 Series + Conv.	325i, 325Ci, 325iT SULEV (PZEV)
Check battery state-of-charge indicator and charge if required.	•	•
Check lighting system, i.e.: headlights, foglights, parking, back-up, license plate, interior (including map reading lights), glove box, flashlight, illuminated makeup mirrors, luggage compartment/ area lights.	•	•
Check instrument panel and dashboard illumination.	•	•
Check all warning/indicator lights, check control.	•	•
Check turn signals, hazard warning flashers, brake lights, horns, headlight dimmer and flasher switch.	•	•
Check wipers and washer system(s); wiper blades, washer jet positions.	•	•
Check condition and function of safety belts.	•	•
Visually examine all SRS airbag units for torn covers, obvious damage or attachment of decals, decorations or accessories.	•	•
Check central locking/double lock.	•	•
Check operation of all latches.	•	•
Check heater/air conditioner blower, rear window defogger.	•	•
Check rear view mirrors.	•	•
Activate automatic roll-over protection system via OBD plug. Note: First remove hardtop/lower top.	•	
Lubricate convertible top sliding linkage covers.	•	

Final Inspection

Road test with check of brakes, suspension, steering, clutch/manual transmission or automatic transmission.	•	•
---	---	---

Inspection II

Includes all items listed under Inspection I, and the following checks and maintenance operations.

Engine Compartment

	3 Series + Conv.	325i, 325Ci, 325iT SULEV (PZEV)
Replace air cleaner element. (Note: Reduce replacement interval in dusty operating conditions).	•	•

Brake Fluid Service

Replace brake fluid every 2 years (time interval begins from the vehicle's production date).	•	•
--	---	---

Oxygen Sensor Service

Replace Oxygen Sensor every 120,000 miles (non-SMG).	•	
Replace Oxygen Sensor every 100,000 miles (only SMG).	•	
Replace Oxygen Sensor every 150,000 miles.		•

Spark Plug Service

Replace spark plugs every 100,000 miles.	•	•
--	---	---

Automatic Transmission Service

Replace ATF every 100,000 miles.	•	•
----------------------------------	---	---

	Record of Spark Plug Replacement (Every 100,000 Mi.)		Record of Oxygen Sensor replacement (Every 120,000 Miles) (SMG: 100,000 Miles)		Record of Oxygen Sensor replacement for SULEV (PZEV) (Every 150,000 Miles)		Record of brake/clutch fluid changes (Every 2 years)	ATF change (Every 100,000 miles)
	Date	Mileage	Date	Mileage	Date	Mileage		
Speedometer (Odometer Memory) changed: Mileage _____ Date _____								
Speedometer (Odometer Memory) changed: Mileage _____ Date _____								

BMW Inspection II

Date/Stamp/Signature

BMW Inspection II

Date/Stamp/Signature

BMW Inspection II

Date/Stamp/Signature

BMW Engine Oil Service

Date/Stamp/Signature

BMW Engine Oil Service

Date/Stamp/Signature

BMW Engine Oil Service

Date/Stamp/Signature

BMW Inspection I

Date/Stamp/Signature

BMW Inspection I

Date/Stamp/Signature

BMW Inspection I

Date/Stamp/Signature

BMW Engine Oil Service

Date/Stamp/Signature

BMW Engine Oil Service

Date/Stamp/Signature

BMW Engine Oil Service

Date/Stamp/Signature

BMW Engine Oil Service

Date/Stamp/Signature

BMW Inspection I

Date/Stamp/Signature

BMW Engine Oil Service

Date/Stamp/Signature

BMW Inspection II

Date/Stamp/Signature

BMW Engine Oil Service

Date/Stamp/Signature

BMW Inspection I

Date/Stamp/Signature

BMW Engine Oil Service

Date/Stamp/Signature

BMW Inspection II

Date/Stamp/Signature

BMW Engine Oil Service

Date/Stamp/Signature

BMW Inspection I

Date/Stamp/Signature

BMW Engine Oil Service

Date/Stamp/Signature

BMW Inspection II

Date/Stamp/Signature

BMW Inspection II

Date/Stamp/Signature

BMW Inspection II

Date/Stamp/Signature

BMW Inspection II

Date/Stamp/Signature

BMW Engine Oil Service

Date/Stamp/Signature

BMW Engine Oil Service

Date/Stamp/Signature

BMW Engine Oil Service

Date/Stamp/Signature

BMW Inspection I

Date/Stamp/Signature

BMW Inspection I

Date/Stamp/Signature

BMW Inspection I

Date/Stamp/Signature

BMW Engine Oil Service

Date/Stamp/Signature

BMW Engine Oil Service

Date/Stamp/Signature

BMW Engine Oil Service

Date/Stamp/Signature

Emission Control Maintenance Schedule

3 Series and 325i, 325Ci, 325iT SULEV (PZEV)

The maintenance schedule as shown is required for the proper functioning of the emission control systems for optimum vehicle performance and fuel economy.

Abbreviations:

I - Inspect

R - Replace part(s) and/or fluid listed

Basic Engine

Engine oil.....
 Engine oil filter.....

Fuel System

Air filter.....

Ignition System

Spark plugs.....

Emission Control Components

Oxygen sensor.....

3 Series

	Oil Service	Inspection I	Oil Service	Inspection II
Engine oil.....	R	R	R	R
Engine oil filter.....	R	R	R	R
Air filter.....				R
Spark plugs.....	Replace at intervals of 100,000 miles			
Oxygen sensor.....	Replace at intervals of 120,000 miles (SMG: 100,000 miles)			

325i, 325Ci, 325iT SULEV (PZEV)

	Oil Service	Inspection I	Oil Service	Inspection II
Engine oil.....	R	R	R	R
Engine oil filter.....	R	R	R	R
Air filter.....				R
Spark plugs.....	Replace at intervals of 100,000 miles			
Oxygen sensor.....	Replace at intervals of 150,000 miles			

Oxygen Sensor Service: The oxygen sensor deteriorates strictly on a mileage basis and must therefore be replaced to maximize vehicle fuel economy and minimize exhaust pollution.

The mileage interval varies according to individual driving conditions and is determined by the service interval indicator.

Battery Care

If your car is driven only for short distances of less than 10 miles over a prolonged period of time, without an occasional drive at highway speeds, the engine's charging system will not maintain the battery. Insufficient use of the vehicle could result in short term starting problems and in the long term could damage the battery.

In case the car is not operated for more than four weeks it is advisable to:

- a) consider using a proper trickle charger, following the charger manufacturer's instructions, to maintain the battery's state of charge; or
- b) consult your BMW center regarding battery removal. Once removed, the battery must be charged and stored in a cool, dry place where it can be protected from freezing. If the battery will be stored for over 3 months, it must be recharged every 3 months, or else it will become damaged and useless.

Please consult with your BMW center for further guidance and information.

Corrosion Protection

Extensive corrosion protection measures implemented by BMW now make it possible to offer a twelve-year limited mileage anti-corrosion warranty against rust perforation on your vehicle provided that the vehicle is maintained in accordance with the provisions of the New Vehicle Limited Warranty as outlined in the Warranty Section of this Statement (page 30).

The major degree of corrosion protection is due to the electrophoretic dip painting process which cathodically deposits paint particles on all body parts, attracting paint particles into the minutest cavities or seams. Body parts are designed to provide optimum corrosion protection.

During manufacture, exterior body parts receive an additional corrosion protection coat. Hood, trunk, doors and other body parts with metal folds are coated with PVC and sealed from the outside.

All floor panels receive a resilient coating of PVC for maximum protection against damage due to stones, etc.

Corrosion protection materials tested over many years are applied to the surfaces of cavities and to the entire underside of the vehicle during and after assembly.

Requirements for maintaining the twelve-year unlimited mileage anti-corrosion warranty are outlined in the Warranty Section of this Statement (page 32).

Restoring corrosion protection

Please take care that anti-corrosion material is replaced when your car is repaired after body or chassis damage.

BMW will not accept any liability for any parts and accessories not approved by BMW.

Underbody maintenance

The underbody has to be cleaned at least once a year, in spring, with plain water in order to remove mud, chemical sediments and other deposits. If those materials are not removed, corrosion (rust) will occur.

Your BMW center will do this anti-corrosion service for you.

WARNING

Do not apply additional undercoating or rust-proofing on or near the exhaust manifold, exhaust pipes, catalytic converter or heat shields. During driving, the substance used for undercoating could overheat and cause a fire.

Body Inspection

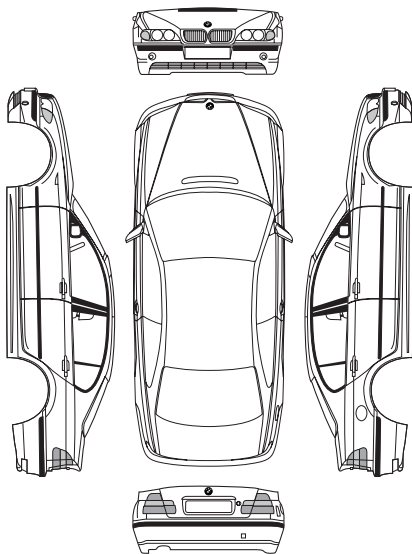

Vehicle inspected and repaired if necessary to BMW standards required by BMW twelve year unlimited mileage anti-corrosion warranty

- Yes
- No
- Partially*

*Remarks—explain (use repair order if necessary)

Show damage location above with codes:

- X Stone damage O Dent
- △ Scratch // Collision damage

Undercoating damage (explain in remarks)

The undersigned herewith confirms that this inspection has been carried out by the BMW center below and this BMW center has given notification of any body repairs necessary.

Customer's signature _____ Date _____

Performed by BMW center/Stamp with Code

BMW center authorized signature _____

Body Inspection

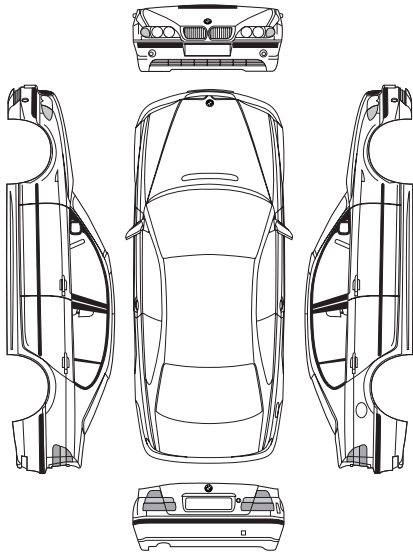

Show damage location above with codes:

X Stone damage O Dent
△ Scratch // Collision damage

Undercoating damage (explain in remarks)

Vehicle inspected and repaired if necessary to BMW standards required by BMW twelve year unlimited mileage anti-corrosion warranty

- Yes
- No
- Partially*

*Remarks—explain (use repair order if necessary)

The undersigned herewith confirms that this inspection has been carried out by the BMW center below and this BMW center has given notification of any body repairs necessary.

Customer's signature _____ Date _____

Performed by BMW center/Stamp with Code

BMW center authorized signature _____

Body Inspection

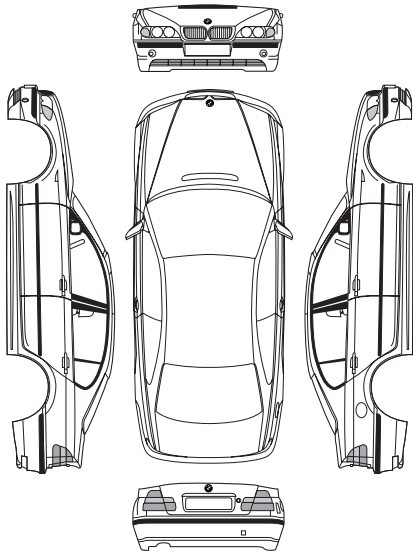

Show damage location above with codes:

X Stone damage O Dent
△ Scratch ▨ Collision damage

Undercoating damage (explain in remarks)

Vehicle inspected and repaired if necessary to BMW standards required by BMW twelve year unlimited mileage anti-corrosion warranty

- Yes
- No
- Partially*

*Remarks—explain (use repair order if necessary)

The undersigned herewith confirms that this inspection has been carried out by the BMW center below and this BMW center has given notification of any body repairs necessary.

Customer's signature _____ Date _____

Performed by BMW center/Stamp with Code

BMW center authorized signature _____

Body Inspection

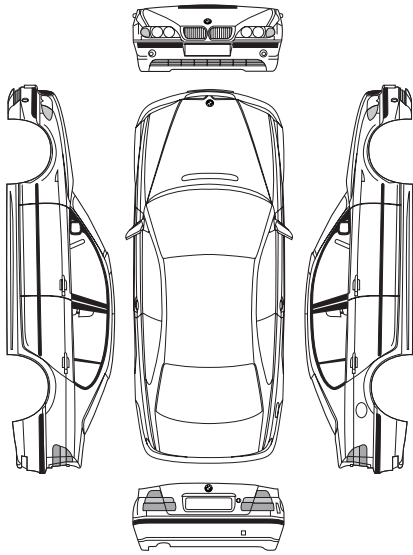

Show damage location above with codes:

X Stone damage O Dent
 △ Scratch // Collision damage
 Undercoating damage (explain in remarks)

Vehicle inspected and repaired if necessary to BMW standards required by BMW twelve year unlimited mileage anti-corrosion warranty

- Yes
- No
- Partially*

*Remarks—explain (use repair order if necessary)

The undersigned herewith confirms that this inspection has been carried out by the BMW center below and this BMW center has given notification of any body repairs necessary.

Customer's signature _____ Date _____

Performed by BMW center/Stamp with Code

BMW center authorized signature _____

Body Inspection

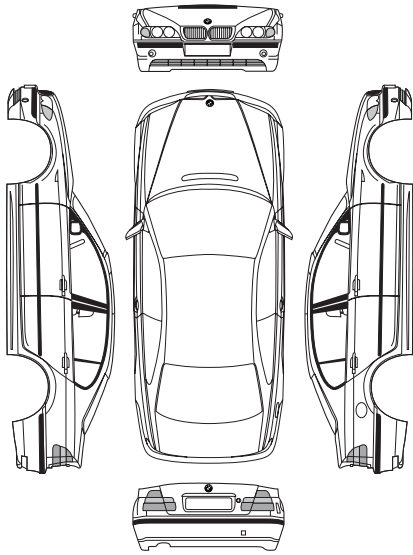

Undercoating damage (explain in remarks)

Show damage location above with codes:
 X Stone damage O Dent
 △ Scratch // Collision damage

Vehicle inspected and repaired if necessary to BMW standards required by BMW twelve year unlimited mileage anti-corrosion warranty

- Yes
- No
- Partially*

*Remarks—explain (use repair order if necessary)

The undersigned herewith confirms that this inspection has been carried out by the BMW center below and this BMW center has given notification of any body repairs necessary.

Customer's signature _____ Date _____

Performed by BMW center/Stamp with Code

BMW center authorized signature _____

Body Inspection

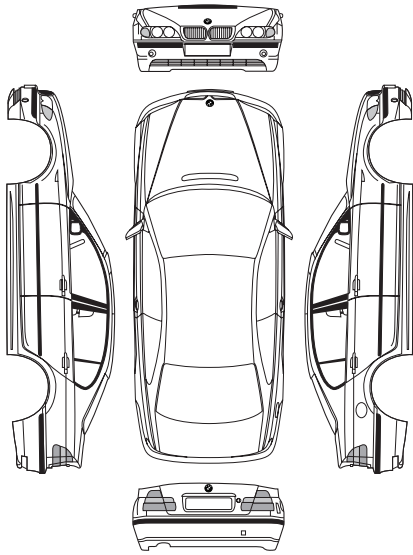

Diagram showing front, rear, top, and side views of a car for damage inspection.

Show damage location above with codes:

X Stone damage O Dent
 △ Scratch // Collision damage
 Undercoating damage (explain in remarks)

Vehicle inspected and repaired if necessary to BMW standards required by BMW twelve year unlimited mileage anti-corrosion warranty

- Yes
- No
- Partially*

*Remarks—explain (use repair order if necessary)

The undersigned herewith confirms that this inspection has been carried out by the BMW center below and this BMW center has given notification of any body repairs necessary.

Customer's signature _____ Date _____

Performed by BMW center/Stamp with Code

BMW center authorized signature _____

Customer Assistance Information

Your satisfaction with our product and the services provided by authorized BMW centers is of great importance to us. We take pride in our product, as does the BMW center who services it. If you should ever have a question regarding your BMW center's service or your BMW's performance, we recommend that you contact your authorized BMW center. Should you travel to an unfamiliar area, the BMW center directory provided at the time of delivery will help you locate the nearest authorized BMW center. The centers listed are equipped to help you with all matters related to your BMW vehicle.

When contacting an authorized BMW center, we suggest that depending upon the nature of your contact, you discuss it with either the Sales, Service, or Parts Manager.

As all matters are resolved at the BMW center level, it is important that they be given the opportunity to provide a solution. Should you feel that you were not provided with the proper response, we urge you to contact the General Manager or BMW Center Operator.

Despite the best intentions of all parties, a misunderstanding may occur between you and your BMW center. Should this occur and you require further assistance, you may wish to contact the BMW NA Customer Relations Department at 1- 800-831-1117 or through our website at www.bmwusa.com. When contacting us, we ask that you provide the following information:

1. Your name, address and telephone number.
2. Vehicle Identification Number (last seven digits).
3. Vehicle's delivery date.
4. Vehicle mileage.
5. Selling BMW center's name.

6. Servicing BMW center's name.

7. Description of the problem.

A BMW NA Customer Relations Representative will carefully review all the facts involved and let you know what further action will be taken in conjunction with your BMW center. Please remember: the first step in resolving a complaint is to contact the authorized BMW center that performed the work on your vehicle. They have the necessary equipment and the personnel to achieve this goal.

We are confident that every effort will be made to ensure your satisfaction.

Customer Assistance - Notification

During a specific period (usually the earlier of 12 months or 12,000 miles, though this period varies by state), some states require us or our authorized BMW center, to repair in a reasonable number of attempts, any defect or condition which substantially impairs the use, value, or safety of a new vehicle sold, leased or registered in that state.

A "reasonable number of attempts" is generally defined as (i) two or more attempts to repair the same defect (the number of attempts may vary by state) or (ii) that the same defect has caused the vehicle to be out of service by reason of repair for more than 30 days (this period may vary by state), except for delays created by conditions beyond our control.

If we are unable to correct a defect or condition covered by these statutes in a reasonable number of attempts, we may be obligated either to replace the vehicle or reimburse the owner/lessee in an amount equal to the purchase price or lease payments paid by the owner/lessee, less the amount directly attributable to use of the vehicle by the owner/lessee.

YOU SHOULD SEND WRITTEN NOTIFICATION DIRECTLY TO BMW OF NORTH AMERICA OF THE EXISTENCE OF AN ALLEGED DEFECT. SEND WRITTEN COMMUNICATION TO THE NATIONAL CUSTOMER RELATIONS DEPARTMENT ADDRESS LISTED BELOW.

**BMW OF NORTH AMERICA
CUSTOMER RELATIONS DEPARTMENT
P.O. BOX 1227
WESTWOOD, NEW JERSEY 07675-1227**

Telephone: 1-800-831-1117

BBB Auto Line

If your concern is still not resolved to your satisfaction, BMW offers additional assistance through BBB AUTO LINE in ARKANSAS, CALIFORNIA, IDAHO, IOWA, GEORGIA, MINNESOTA and PENNSYLVANIA. BBB AUTO LINE is a dispute resolution program administered by the Council of Better Business Bureaus. BBB AUTO LINE resolves disputes through mediation or arbitration. Mediation is an informal proceeding whereby a neutral third party (mediator) helps the parties to find an acceptable resolution. Arbitration is also an informal proceeding in which an impartial third party renders a decision after a hearing at which both parties have an opportunity to be heard. You can select mediation or arbitration or both.

The program is free of charge to you, the consumer but there are some minimum requirements for participation in the program. Please contact BBB AUTO LINE at the address or phone number listed below for more details:

**BBB AUTO LINE
4200 Wilson Boulevard, Suite 800
Arlington, VA 22203
1 (800) 955-5100**

If you wish to use the program and you qualify for participation, you will be required to provide the following information:

- > Your name and address
- > The vehicle identification number (VIN)
- > The make, model and year of your vehicle
- > A description of the problem with your vehicle.

BBB AUTO LINE will also ask you for other information that may help resolve your concerns, such as the purchase price of your vehicle, any mileage at the time of purchase, the current mileage, and copies of repair orders.

BBB AUTO LINE will notify you when your claim has been filed. If you decide to arbitrate you may attend the hearing in person or by telephone. You may bring witnesses and give supporting evidence. You may also submit

your claim in writing and ask for a decision on the documents you submit, without attending a hearing. BBB AUTO LINE will usually render a decision within 40 days from the time you file your complaint. The decision is binding on BMW if you decide to accept it. BMW must comply with the decision within the time frame specified by the arbitrator.

Important: You must use BBB AUTO LINE before asserting in court any rights or remedies created by the Magnuson Moss Warranty Act, ("The Act") 15 U.S.C. Sec. 2301, et seq. You may also be required to use BBB AUTO LINE before seeking remedies under your state's "Lemon Law". If you choose to seek redress by pursuing rights and remedies not created by Title 1 of Magnuson Moss Warranty Act, prior resort to the BBB AUTO LINE is not required by any provision of the Act.

California Residents

1. BMW OF NORTH AMERICA, LLC ("BMW") participates in **BBB AUTO LINE**, a mediation/arbitration program administered by the Council of Better Business Bureaus [4200 Wilson Boulevard, Arlington, Virginia 22203] through local Better Business Bureaus. The Arbitration Certification Program of the California Department of Consumer Affairs has certified **BBB AUTO LINE** and BMW.

2. If you have a problem arising under a BMW written warranty, we encourage you to bring it to our attention. If we are unable to resolve it, you may file a claim with **BBB AUTO LINE**. Claims must be filed with **BBB AUTO LINE** within six (6) months after the expiration of the warranty.

3. To file a claim with **BBB AUTO LINE**, call 1-800-955-5100. There is no charge for the call.

4. In order to file a claim with **BBB AUTO LINE**, you will have to provide your name and address, the brand name and vehicle identification number (VIN) of your vehicle, and a statement of the nature of your problem or complaint. You will also be asked to

provide: the approximate date of your acquisition of the vehicle, the vehicle's current mileage, the approximate date and mileage at the time any problem(s) were first brought to the attention of BMW or one of our dealers, and a statement of the relief you are seeking.

5. **BBB AUTO LINE** staff may try to help resolve your dispute through mediation. If mediation is not successful, or if you do not wish to participate in mediation, claims within the program's jurisdiction may be presented to an arbitrator at an informal hearing. The arbitrator's decision should ordinarily be issued within 40 days from the time your complaint is filed; there may be a delay of 7 days if you did not first contact BMW about your problem, or a delay of up to 30 days if the arbitrator requests an inspection/report by an impartial technical expert or further investigation and report by **BBB AUTO LINE**.

6. You are required to use **BBB AUTO LINE** before asserting in court any rights or remedies conferred by California Civil Code Section 1793.22. You are not required to use BBB AUTO LINE before pursuing rights and remedies under any other state or federal law. "You are also required to use **BBB AUTO LINE** before exercising rights or seeking remedies created by Title I of the Magnuson-Moss Warranty Act, 15 U.S.C. sec. 2301 et seq. If you choose to seek redress by pursuing rights and remedies not created by California Civil Code Section 1793.22 or Title I of the Magnuson-Moss Warranty Act, resort to **BBB AUTO LINE** is not required by those statutes."

7. California Civil Code Section 1793.2(d) requires that, if BMW or its representative is unable to repair a new motor vehicle to conform to the vehicle's applicable express warranty after a reasonable number of attempts, BMW may be required to replace or repurchase the vehicle. California Civil Code Section 1793.22(b) creates a presumption that BMW has had a reasonable number of attempts to conform the vehicle to its applicable express warranties if, within 18 months from delivery to the buyer or 18,000 miles on the vehicle's odometer, whichever occurs first, *one or more of the following occurs:*

- The same nonconformity [a failure to conform to the written warranty that substantially impairs the use, value or safety of the vehicle] results in a condition that is likely to cause death or serious bodily injury if the vehicle is driven AND the nonconformity has been subject to repair two or more times by BMW or its agents AND the buyer or lessee has directly notified BMW of the need for the repair of the nonconformity; OR
- The same nonconformity has been subject to repair 4 or more times by BMW or its agents AND the buyer has notified BMW of the need for the repair of the nonconformity; OR
- The vehicle is out of service by reason of repair of nonconformities by BMW or its agents for a cumulative total of more than 30 calendar days after delivery of the vehicle to the buyer.

NOTICE TO BMW AS REQUIRED ABOVE SHALL BE SENT TO THE FOLLOWING ADDRESS:

**BMW of North America, LLC
Customer Relations Department
P.O. Box 1227
Westwood, New Jersey 07675-1227
1 (800) 831-1117**

8. The following remedies may be sought in BBB AUTO LINE: repairs, reimbursement for money paid to repair a vehicle or other expenses incurred as a result of a vehicle nonconformity, repurchase or replacement of your vehicle and compensation for damages and remedies available under BMW's written warranty or applicable law.

9. The following remedies may **not** be sought in **BBB** AUTO LINE: punitive or multiple damages, attorneys' fees, or consequential damages other than as provided in California Civil Code Section 1794(a) and (b).

10. You may reject the decision issued by a **BBB** AUTO LINE arbitrator. If you reject the decision, you will be free to pursue further legal action. The arbitrator's decision and any findings will be admissible in a court action.

11. If you accept the arbitrator's decision, BMW will be bound by the decision, and will comply with the decision within a reasonable time not to exceed 30 days after we receive notice of your acceptance of the decision.

12. Please call **BBB** AUTO LINE at 1-800-955-5100 for further details about the program.

BMW Import Processing Centers

As a BMW owner, you will experience BMW quality first hand. Our dedication to excellence in design, engineering, and service is among the best in the world. And we invest heavily every year in our people and facilities to ensure that our quality standards are consistently applied from the factory to the BMW center. Part of that investment program is devoted to our multi-million-dollar Import Processing Centers staffed by our highly trained specialists.

At these state-of-the-art facilities, each BMW is given a thorough inspection after its transatlantic shipment to the United States. Imperfections in the mechanical and electrical systems or damage to the sheet metal, paint, trim or other components of the vehicle which may occur during transportation from the factory to the United States are normally detected and corrected at the Import Processing Centers in the United States. Any defect in material or workmanship which occurs during the warranty period is covered under the New Vehicle Limited Warranty.

Special Programs

SOMETIMES BMW OF NORTH AMERICA OFFERS A SPECIAL ADJUSTMENT PROGRAM TO PAY ALL OR PART OF THE COST OF CERTAIN REPAIRS BEYOND THE TERMS OF THE WARRANTY. CHECK WITH YOUR BMW CENTER TO DETERMINE WHETHER ANY ADJUSTMENT PROGRAM IS APPLICABLE TO YOUR MOTOR VEHICLE.

BMW Roadside Assistance

The BMW Roadside Assistance Program reflects BMW's commitment to your complete satisfaction with the BMW ownership experience.

It is available for U.S. version BMWs in all 50 states, Canada, and Puerto Rico 24 hours a day, 365 days a year.

It is a valuable benefit provided to you at no additional cost. (Subject to certain limitations and exclusions noted on pages 26-28).

Owner's Eligibility

You are covered if your vehicle is:

- A new BMW automobile, distributed by BMW NA, and purchased at an authorized BMW center, OR;
- A new BMW automobile, purchased under the BMW NA European Delivery Plan, OR;
- A new, U.S. version, BMW automobile purchased under the Diplomatic or Military Sales programs, operated in any of the 50 states, Canada and Puerto Rico.

Coverage is provided for the vehicle itself, regardless of the driver. Protection is concurrent with the New Vehicle Limited Warranty.

Getting Started

A temporary Roadside Assistance Identification Card can be found inside of your vehicle portfolio. It contains the 24-hour toll-free number for Roadside Assistance.

For your convenience a decal, showing the same information as the ID card, has been affixed to the tool kit cover on the trunk lid.

In a few weeks you will receive a permanent BMW Roadside Assistance ID card by mail. The date of purchase and the vehicle identification number (VIN) are embossed on the card.

This card should be carried by the driver of your BMW automobile.

Calling For Assistance

The toll-free BMW Roadside Assistance number is answered by a BMW Roadside Assistance service representative. In order for you to receive quick and reliable services, it is essential that you should provide detailed and accurate information to the service representative.

Be prepared to give:

1. Your name and address.
2. Your complete Vehicle Identification Number (found on your vehicle registration or your permanent BMW Roadside Assistance ID card).
3. Model description of your vehicle.
4. Date of purchase.
5. License plate number of your vehicle.
6. Vehicle location (including nearby cross-roads/intersections, highway mile markers, street numbers, landmarks, etc.).
7. Location you are calling from (including a telephone number where you can be reached). If you are calling from a public phone wait there for the return call. Do not leave this location without informing the Roadside Assistance service representative.
8. A description of your vehicle's problem. Specific and accurate information will enable the Roadside Assistance service representative to provide the proper help.

Services

From the information you provide, the BMW Roadside Assistance service representative will determine the type of help required.

Dispatch Service

A service provider will be dispatched to the site of your disabled vehicle.

On-Site Assistance

On-site service for vehicle disablements such as flat tires, dead batteries, and out of fuel conditions is provided up to a maximum of \$100.00 per incident by BMW Roadside Assistance.

The cost for parts and fuel, when used on-site, are the responsibility of the owner/driver. The New Vehicle Limited Warranty does not cover any of the above on-site services.

Lock-Out

For security purposes, the driver will need to prove ownership by presenting proper documentation, i.e., a valid drivers license, registration, etc. Lock-out service will be provided up to a maximum of \$100.00 per incident.

Towing Service

In the event of a mechanical breakdown normally covered under the New Vehicle Limited Warranty, your vehicle will be transported (at no cost) to the nearest authorized BMW center. Your vehicle is also covered in the event of an accident or collision.

If a breakdown occurs after normal business hours, your vehicle will be transported to a secure location and transported to the nearest authorized BMW center on the next business day.

If you request that the vehicle be taken to a location other than the nearest authorized BMW center, any additional expense will be your responsibility.

However, you may request (at no cost) to be taken to a different BMW center as long as it is within 50 additional miles of the "nearest" BMW center.

Towing requests for vehicles disabled because of casualty, fire, act of God, or violation of law (federal, state or local) are accepted at the expense of the owner/driver.

If it is necessary for you to have your vehicle towed through your own arrangements, **you must contact BMW Roadside Assistance for prior authorization and instructions on claim procedures.** All claims must be submitted within sixty (60) days of the disablement or occurrence, accompanied by the original receipts. Claims received after that time period may not be honored and are subject to the full discretion of BMW Roadside Assistance. If BMW Roadside Assistance is not contacted for "prior" authorization, the maximum coverage for towing situations is \$100.00.

Sign-and-Drive

In most instances, services provided under the BMW Roadside Assistance Program do not require immediate payment.

Usually, you will be able to sign a receipt, so the provider of the service can be reimbursed directly by BMW Roadside Assistance.

Parts, materials and fuel should be paid by you directly to the provider of the services.

Trip Interruption Benefits

Trip interruption benefits are provided for mechanical breakdowns as follows:

- Breakdowns that are warranty related, and;

- Must occur in excess of 100 miles from the driver's residence, and;
- Repairs cannot be completed during normal business hours on the same day of breakdown.

Reimbursements will be made for meals, lodging, car rentals, and alternate transportation to bring the driver and the BMW automobile together after the vehicle has been repaired by an authorized BMW center. Original receipts must accompany all reimbursement requests.

Trip interruption coverage is limited to \$750.00 per incident, to a maximum of five days per incident.

Always contact BMW Roadside Assistance for trip interruption benefits. They will assist in making all the necessary arrangements.

Car Rental Discounts

Discounts of up to 30% are available from Alamo, Avis, Dollar, Hertz and National car rental companies. Benefits may vary with each company and location, and are subject to change without notice.

Simply display your BMW Service Card (showing the applicable Plan number) during reservation and at the time of rental to secure your discount.

Auto Valet Service

Should there be a need beyond BMW Roadside Assistance, Auto Valet will provide a personal assistant who will help in every way to get you to your final destination. Auto Valet will help you locate a rental car or taxi agency, hotel or even help procure airline reservations.

In event of an emergency, this service will assist you in getting information out to the proper party whether it's business or personal. If unable to contact, the message relay service will document the information, and will make

reasonable efforts to deliver the message to the message recipient.

Personalized Trip Routing

Leave the planning to us. Simply give one of our Roadside Assistance service representatives a call, and we'll provide you with detailed, easy to read, computerized trip itinerary and companion map package.

Exclusions

Specifically excluded from coverage are:

- Fines, taxes, or impound towing fees caused by a violation of local or state law.
- Expenses related to hazardous weather conditions (removal from snow, ice, etc.).
- Expenses for the removal of snow tires, and mounting or removal of snow chains.

Services provided by Cross Country Motor Club, Inc., Boston, MA 02155, except in Alaska, California, Hawaii, Oregon, Wisconsin and Wyoming where services are provided by Cross Country Motor Club of California, Inc., Boston, MA 02155.

The BMW Roadside Assistance Program is not a warranty and does not affect your rights under the New Vehicle Limited Warranty.

Summary of BMW Limited Warranties

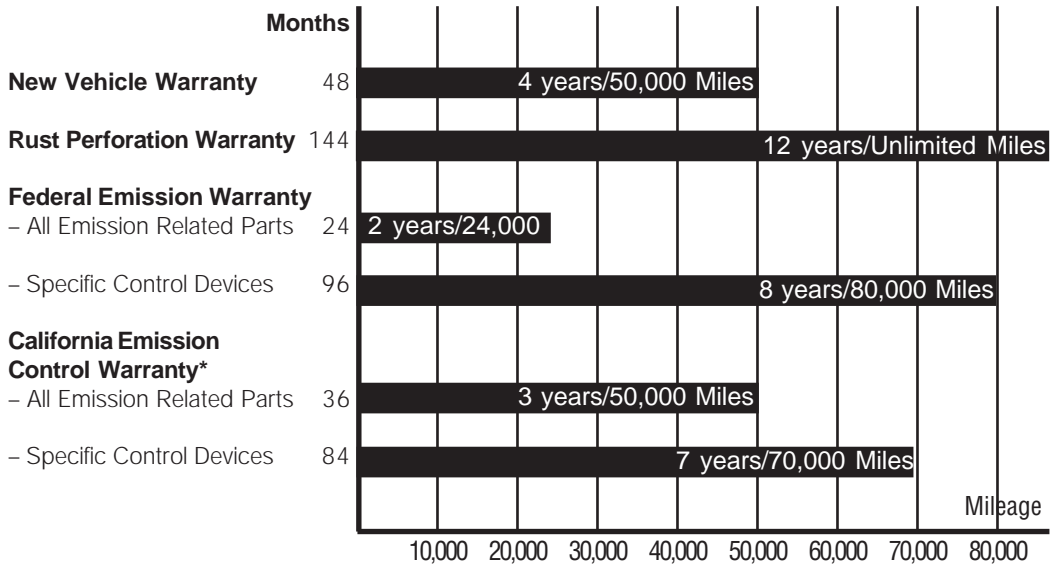

* The California Emissions Control System Limited Warranty applies to all 2005 U.S. specification BMW vehicles sold, leased, and/or registered in California, Maine, Massachusetts or Vermont and all 2005 U.S. specification BMW SULEV (PZEV) vehicles sold, leased, and/or registered in California, Maine, Massachusetts, New York or Vermont.

New Vehicle Limited Warranty - 2005 3 Series Models (except M3) (Valid only in the U.S.A. and Puerto Rico)

Warrantor

BMW NA warrants 2005 U.S. specification vehicles distributed by BMW NA or sold through the BMW NA European Delivery Program against defects in materials or workmanship to the first retail purchaser, and each subsequent purchaser.

Warranty Period

The warranty period is 48 months or 50,000 miles, whichever occurs first.

Warranty Begins

This warranty begins on the date of first retail sale, or the date the vehicle is first placed in service as a demonstrator or company vehicle, whichever is earlier.

Warranty Coverage

To obtain service under this warranty, the vehicle must be brought, upon discovery of a defect in material or workmanship, to the workshop of any authorized BMW center, during normal business hours. The BMW center will, without charge for parts or labor, either repair or replace the defective part(s) using new or authorized remanufactured parts. The decision to repair or replace said part(s) is solely the prerogative of BMW NA. Parts for which replacements are made become the property of BMW NA.

In all cases, a reasonable time must be allowed for warranty repairs to be completed after the vehicle is received by the BMW center.

Safety Belt Warranty - Kansas

Safety belts are covered under the BMW New Vehicle Limited Warranty for defects in material or workmanship for a period of 10 years,

unlimited mileage from the date of purchase. In order to be eligible for this coverage, the vehicle must be a new car retailed in the State of Kansas and the repair performed by an authorized BMW center in Kansas.

Towing/Other Owner Benefits

A 24-hour Roadside Assistance Program is available to every BMW owner during the new vehicle warranty period.

Roadside assistance and other owner benefits are available by calling:

1-800-332-4269

For additional details on towing and other owner benefits please refer to the BMW Roadside Assistance section of this Statement (page 26).

Other Items

Wheel alignment, balancing and wiper blade inserts are covered up to 2,000 miles.

Items which are subject to wear and tear or deterioration due to driving habits or conditions, such as brake pads/linings, brake discs, clutch disc, pressure plate, filters, upholstery, trim and chrome items, paint finish, drive belts, glass, and similar items, are specifically limited to defects in material or workmanship.

This warranty does not apply to the following:

Damage which results from negligence, improper operation of the vehicle, improper repair, lack of or improper maintenance, environmental influences, flood, accident or fire damage, road salt corrosion, or use of improper or contaminated fuel.

Maintenance services and parts when replaced during maintenance such as spark plugs, lubricants, fluids, engine tuneup parts, replacement of filters, coolant, and refrigerant.

Failure to maintain the vehicle properly in accordance with the instructions in the Owner's Manual or the Service section of this Statement, that results in the failure of any part of the vehicle.

Modification of the vehicle or installation of any performance accessories or components attached to the vehicle which alters the original engineering and/or operating specifications or which result in damage to the other original components, electrical interference, electrical short, radio static, water leaks and wind noise.

Tires are warranted by their respective manufacturer as detailed in the applicable tire manufacturer's warranty statements. Instructions for proper tire care and maintenance are contained in the Owner's Manual. Should you experience difficulty in obtaining warranty service from a tire manufacturer, your authorized BMW center will assist you in resolving the difficulty.

Non-BMW Parts – While you may elect to use non-genuine BMW parts for maintenance or repair services, BMW NA is not obligated to pay for repairs that include non-genuine BMW parts or for any damage resulting from the use of non-genuine parts.

BMW will not accept any liability for any parts and accessories not approved by BMW.

This warranty shall be null and void if the vehicle identification number has been altered or cannot be read, if the odometer has been replaced or altered and the true mileage cannot be determined, if the vehicle has been declared a total loss or sold for salvage purposes, or if the vehicle has been used in any competitive event.

General

These warranties give you specific legal rights, and you may also have other rights which vary from state to state.

THE DURATION OF ANY IMPLIED WARRANTIES, INCLUDING THE IMPLIED WARRANTY OF MERCHANTABILITY, IS LIMITED TO THE DURATION OF THE EXPRESS WARRANTIES HEREIN. BMW NA HEREBY EXCLUDES INCIDENTAL AND CONSEQUENTIAL DAMAGES, INCLUDING LOSS OF TIME, INCONVENIENCE, OR LOSS OF USE OF THE VEHICLE, FOR ANY BREACH OF ANY EXPRESS OR IMPLIED WARRANTY, INCLUDING THE IMPLIED WARRANTY OF MERCHANTABILITY, APPLICABLE TO THIS PRODUCT.

Some states do not allow limitations on how long an implied warranty lasts, or the exclusion or limitation of incidental or consequential damages, so the above limitations and exclusions may not apply to you.

The BMW Certified Pre-Owned Limited Warranty:

The BMW Certified Pre-Owned limited warranty is applicable to the retail purchaser and each subsequent retail purchaser (not for resale purposes) of the CPO vehicle sold through an authorized BMW center for 2 years or 50,000 miles from the effective date, whichever occurs first.

Limited Warranty - Rust Perforation 2005 Models

BMW NA warrants this original vehicle against defects in materials or workmanship which will result in rust perforation of the vehicle body for a period of 12 years unlimited mileage, commencing on the date of first retail sale, or the date the vehicle is first placed in service as a demonstrator or company vehicle, whichever is earlier.

To obtain service under this warranty, the vehicle must be brought, upon discovery of any rust perforation, to the workshop of any authorized BMW center. This BMW center will, without charge for parts or labor, either repair or replace the defective part(s). The decision to repair or replace said part(s) is solely the prerogative of BMW of North America. Parts for which replacements are made become the property of BMW of North America.

REQUIRED MAINTENANCE:

In order to keep this warranty in effect, the vehicle must be inspected at every BMW Inspection II (at least every two years). Any areas requiring preventative maintenance must be repaired. (THIS INSPECTION/ MAINTENANCE IS AT THE OWNER'S EXPENSE).

The Inspection/Maintenance consists of:

- a. Washing the chassis before inspection, if necessary, due to dirt accumulation.
- b. Repairing any damages to undercoating or paint due to stone chips, gravel erosion, scratches, or other external influences.

BMW of North America makes no other express warranty on this product except the new car warranty or the warranty as to the emission control system. THE DURATION OF ANY IMPLIED WARRANTIES, INCLUDING THE IMPLIED WARRANTY OF MERCHANTABILITY, IS LIMITED TO THE DURATION OF THE EXPRESS WARRANTIES HEREIN.

BMW OF NORTH AMERICA HEREBY EXCLUDES INCIDENTAL AND CONSEQUENTIAL DAMAGES, INCLUDING LOSS OF TIME, INCONVENIENCE, OR LOSS OF USE OF THE VEHICLE, FOR ANY BREACH OF ANY EXPRESS OR IMPLIED WARRANTY, INCLUDING THE IMPLIED WARRANTY OF MERCHANTABILITY, APPLICABLE TO THIS PRODUCT.

Some states do not allow limitations on how long an implied warranty lasts, or the exclusion or limitation of incidental or consequential damages, so the above limitations and exclusions may not apply to you.

This warranty gives you specific legal rights, and you may also have other rights which vary from state to state. Any legal claim or action arising from any express or implied warranty contained herein must be brought within 12 months of the date it arises.

This warranty does not apply to the following:

- a. Damage caused by negligence, improper accident damage repairs, or improper use.
- b. Damage attributable to failure to perform required inspections/maintenance at the specified intervals or in accordance with the BMW rust inspection/maintenance program instructions. Proof must be provided by a paid invoice or filling in the appropriate boxes in the Service Section of this Statement.

BMW will not accept any liability for any parts and accessories not approved by BMW.

This warranty shall be null and void if the vehicle identification number has been altered or cannot be read, if the odometer has been replaced or altered and the true mileage cannot be determined, if the vehicle has been declared a total loss or sold for salvage purposes, or if the vehicle has been used in any competitive event.

Federal Emissions System Defect Warranty (Valid only in the U.S.A. and Puerto Rico)

This warranty applies only to U.S. specification vehicles distributed by BMW of North America (BMW NA) or sold through the BMW NA European Delivery Program.

In accordance with the defect warranty provisions of section 207(b) of the Clean Air Act, BMW NA warrants to the first retail purchaser, and each subsequent purchaser, that the car (a) was designed, built and equipped so as to conform, at the time of sale, with all regulations of the U.S. Environmental Protection Agency applicable at the time of manufacture and (b) is free from defects in materials and workmanship which would cause it to fail to conform with applicable regulations for a period of 2 years or 24,000 miles, whichever occurs first, except for specific emission control components (as listed on page 37), for which the warranty period is 8 years or 80,000 miles, whichever occurs first.

This warranty begins on the date of first retail sale, or the date the vehicle is first placed in service as a demonstrator or company vehicle, whichever is earlier.

Warranty claims must be made as soon as reasonably possible after a defect is discovered. To make a claim, the car must be brought to any authorized BMW center during normal business hours.

The BMW center will, without charge for parts or labor (including diagnosis), either repair or replace the defective part, if any. The decision whether to repair or replace said parts is solely the prerogative of BMW NA and must be expected to correct the failure of the warranted part. Parts for which replacements are made become the property of BMW NA. In all cases, a reasonable time must be allowed for warranty repairs to be completed after the car is received by the BMW center.

For assistance in determining which specific parts or components of your vehicle are covered under this warranty, please contact your BMW center.

It is the owner's responsibility to have all scheduled inspection and maintenance services performed (at the owner's expense), as prescribed in the maintenance schedule for the BMW Emission Control System. Service intervals are computed by the onboard BMW service interval indicator and displayed on the instrument panel. The instructions for proper maintenance and use can be found in the Owner's Manual. It is strongly recommended that any replacement parts used for maintenance, repair or replacement of emission control systems be certified BMW Service Parts or BMW Authorized Remanufactured Parts. Without invalidating this warranty, the owner may elect to have maintenance, repair or replacement of the emission control systems performed by any automotive repair establishment, or elect to use parts other than certified BMW Service Parts. However, the cost of such service or parts will not be covered under this warranty, except in emergency situations. In an emergency situation, where an authorized BMW center or a warranty replacement part is not reasonably available (within 30 days), repairs may be performed at any available service establishment using any equivalent part. BMW NA will reimburse the owner for such emergency repairs (including labor, parts and diagnosis not to exceed BMW NA rates for labor, parts, and diagnosis in said area) that are covered under this warranty. Replaced parts and paid invoices must be presented at a BMW center as a condition of reimbursement for emergency repairs not performed by a BMW center.

The use of replacement parts, which are not of equivalent quality, may impair the effectiveness of the emission control system. If other than certified BMW Service Parts or Authorized Remanufactured Parts are used for maintenance, repair or replacement of components affecting emission control, the owner should obtain assurances that such

parts are warranted by their manufacturer to be equivalent to genuine BMW parts in performance and durability. BMW NA assumes no liability under this warranty with respect to parts other than genuine BMW parts.

However, the use of non-BMW replacement parts or non-EPA certified parts does not invalidate the warranty on other components, unless non-BMW parts or non-EPA certified parts cause damage to warranted parts.

What is not covered

This warranty does not cover malfunctions caused by any of the following: accident, flood, misuse, improper adjustment, modification, alteration, tampering, disconnection, improper or inadequate maintenance, use of leaded fuel or fuels containing more than 10% ethanol, or other oxygenates with more than 2.8% oxygen by weight (i.e., more than 15% MTBE or more than 3% methanol plus an equivalent amount of co-solvent).

The replacement of maintenance parts, such as spark plugs, filters and similar items used in required maintenance services, the repair or replacement of maintenance parts beyond the first required inspection/maintenance, or if the part has been replaced earlier for reasons other than it being defective.

The car or any part of the car unless a failure causes the car to fail to conform to applicable emission regulations.

Any car on which the odometer has been replaced or altered and the true mileage cannot be determined.

The car, if the vehicle identification number is altered or cannot be read, or if the car has been declared a total loss or sold for salvage purposes.

General

These warranties give you specific legal rights, and you may also have other rights which vary from state to state.

THE DURATION OF ANY IMPLIED WARRANTIES, INCLUDING THE IMPLIED WARRANTY OF MERCHANTABILITY, IS LIMITED TO THE DURATION OF THE EXPRESS WARRANTIES HEREIN.

BMW NA HEREBY EXCLUDES INCIDENTAL AND CONSEQUENTIAL DAMAGES, INCLUDING LOSS OF TIME, INCONVENIENCE, OR LOSS OF USE OF THE VEHICLE, FOR ANY BREACH OF ANY EXPRESS OR IMPLIED WARRANTY, INCLUDING THE IMPLIED WARRANTY OF MERCHANTABILITY, APPLICABLE TO THIS PRODUCT.

Some states do not allow limitations on how long an implied warranty lasts, or the exclusion or limitation of incidental or consequential damages, so the above limitations and exclusions may not apply to you. Additionally, if you are a California, Maine, Massachusetts or Vermont resident and your vehicle is registered in that state, your vehicle is eligible for California Emissions Warranty coverage.

These federal warranty provisions also apply to all vehicles sold in all U.S. states and territories regardless of whether a state has enacted state warranty provisions that differ from the federal provisions.

Federal Emissions Performance Warranty (Valid only in the U.S.A. and Puerto Rico)

In those states and jurisdictions that have established periodic vehicle emissions tests to encourage proper vehicle maintenance and require the car to pass an emissions test approved by the U.S. Environmental Protection Agency and:

1. The car was distributed by BMW of North America (BMW NA), or sold through the BMW NA European Delivery Program; and
2. The car has been maintained and operated in accordance with the instructions for proper maintenance and use set forth in the Owner's Manual supplied with the car; and
3. The car fails to conform to the applicable emissions standards of the EPA as judged by an EPA approved emissions test; and
4. The failure to conform results or will result in the owner of the car having to bear a penalty or other sanction (including the denial of the right to use the car) under local state or federal law if the non-conformity is not remedied within a specified period of time.

Then, in accordance with the provisions of section 207(b) of the Clean Air Act, BMW NA warrants that if the car is eligible for coverage under this warranty, any non-conformities in the car, which cause it to fail an EPA-approved emissions test will, without charge for parts or labor (including diagnosis), be adjusted, repaired, or replaced, at the option of BMW NA to proper specifications, in order to make the car comply with applicable emissions standards. The decision to adjust, repair or replace parts is solely the prerogative of BMW NA and must reasonably be expected to correct the failure of the warranted part.

This warranty begins on the date of first retail sale, or the date the vehicle is first placed in service as a demonstrator or company vehicle, whichever is earlier. This warranty continues for a period of 2 years or 24,000 miles, whichever occurs first, except for specific emissions control components (as listed on page 38), for which the warranty period is 8 years or 80,000 miles whichever occurs first.

This warranty is made subject to the terms and conditions that apply to the Emission Control System Warranty and the New Vehicle Limited Warranty.

No claim under this warranty will be denied on the basis of use of a properly installed EPA certified emission part for maintenance and repair.

A vehicle manufacturer may deny an emission performance warranty claim on the basis of an uncertified replacement part used in the maintenance or repair of a vehicle only if the vehicle manufacturer presents evidence that the uncertified replacement part is either defective in materials or workmanship or not equivalent from an emission standpoint to the original equipment part.

Maintenance, replacement, or repair of emission control devices and systems may be performed by any automotive repair establishment or individual using any certified part.

Immediately after the car has failed an EPA approved emission short test, your claim can be made at any authorized BMW center. The BMW center will honor or deny your claim within the time period specified by local or state laws (not to exceed 30 days), to avoid further penalties or sanctions. If the claim is denied, the BMW center will notify you in writing of the reason(s). The BMW center is required by law to honor the claim if notice of denial is not received by the owner within the specified time period.

You may obtain further information concerning the emission warranties, or report violations of warranty terms, by contacting the Director, Field Operations and Support Division (6406J), Environmental Protection Agency, 401 "M" Street, SW, Washington, D.C. 20460.

The following systems are covered by the Federal Emission Performance Warranty for a period of two years or 24,000 miles, whichever occurs first. The specific systems may vary according to model, therefore, all of the systems listed may not be used on your vehicle. For assistance in determining which systems and specific components within these systems apply to your vehicle, please contact your BMW center.

AIR INDUCTION SYSTEM

FUEL METERING SYSTEM

IGNITION SYSTEM

POSITIVE CRANKCASE VENTILATION SYSTEM (PCV)

FUEL EVAPORATIVE CONTROL SYSTEM

EXHAUST SYSTEM

ENGINE EMISSION CONTROL SYSTEM SENSORS/DEVICES

ON BOARD DIAGNOSTIC SYSTEM (OBD)

RELATED PARTS ASSOCIATED WITH THE ABOVE SYSTEMS

The following components and/or system are/ is covered under the Federal Emission Performance Warranty for a period of 8 years or 80,000 miles, whichever occurs first.

CATALYTIC CONVERTER

ENGINE CONTROL MODULE (INCLUDING ON-BOARD DIAGNOSTIC SYSTEM)

For assistance in determining coverage of the specific components of the on-board diagnostic system, please contact your BMW center.

California Emission Control Warranty Statement* Your Warranty Rights and Obligations

The California Air Resources Board and BMW of North America (BMW NA) are pleased to explain the emission control system warranty on your 2005 vehicle. In California, new motor vehicles must be designed, built and equipped to meet the State's stringent anti-smog standards. BMW NA must warrant the emission control system on your vehicle for the periods of time listed below provided there has been no abuse, neglect or improper maintenance of your vehicle.

Your emission control system may include parts such as the fuel injection system, the ignition system, catalytic converter, and engine computer. Also included may be hoses, belts, connectors and other emission-related assemblies.

Where a warrantable condition exists, BMW NA will repair your vehicle at no cost to you including diagnosis, parts and labor.

Manufacturer's Warranty Coverage:

- For 3 years or 50,000 miles or 15 years or 150,000 miles for the SULEV (PZEV), whichever occurs first:
 1. If your vehicle fails a Smog Check inspection, all necessary repairs and adjustments will be made by BMW NA to ensure that your vehicle passes the inspection. This is your emission control system PERFORMANCE WARRANTY.
 2. If any emission-related part on your vehicle is defective, the part will be repaired or replaced by BMW NA. This is your short-term emission control system DEFECTS WARRANTY.
- For 7 years or 70,000 miles whichever occurs first:

If an emission-related part, specially noted on page 41 as having coverage for 7 years or

70,000 miles is defective, the part will be repaired or replaced by BMW NA. This is your long-term emission control system DEFECTS WARRANTY.

Owner's Warranty Responsibilities:

- As the vehicle owner, you are responsible for the performance of the required maintenance listed in your Owner's Manual. BMW NA recommends that you retain all receipts covering maintenance on your vehicle, but BMW NA cannot deny warranty solely for the lack of receipts or for your failure to ensure the performance of all scheduled maintenance.
- You are responsible for presenting your vehicle to an authorized BMW center as soon as a problem exists. The warranty repairs should be completed in a reasonable amount of time, not to exceed 30 days.
- As the vehicle owner, you should also be aware that BMW NA may deny your warranty coverage if your vehicle or part has failed due to abuse, neglect, improper maintenance or unapproved modifications.

If you have any questions regarding your warranty rights and responsibilities, you should contact:

BMW of North America
Customer Relations Department
PO. Box 1227
Westwood, N.J. 07675-1227
Telephone: 1-800-831-1117
Website: www.bmwusa.com

or the

California Air Resources Board
9528 Telstar Avenue
El Monte, CA 91731

*The California Emissions Control System Limited Warranty applies to all 2005 U.S. specification BMW 3 Series vehicles (except M3) sold, leased, and/or registered in California, Maine, Massachusetts, New York or Vermont.

California Emission Control System Limited Warranty*

This warranty applies to California certified vehicles distributed by BMW of North America (BMW NA) or sold through the BMW NA European Delivery Program, registered and operated primarily in California.

BMW NA warrants to the original purchaser and each subsequent owner that the vehicle is:

- (a) designed, built and equipped so as to conform with the applicable California Air Resources Board emission standards.
- (b) free from defects in materials and workmanship which cause any part that can affect emissions to fail to conform with applicable requirements or to fail a California Smog Check test or EPA approved short test for a period of 3 years or 50,000 miles, or 15 years or 150,000 miles for the SULEV (PZEV), whichever occurs first.
- (c) free from defects in materials and workmanship in emission related parts, which are contained in the California Emission Warranty Parts List on page 40, for a period of 7 years or 70,000 miles, whichever occurs first.

This warranty begins on the date of first retail sale, or the date the vehicle is first placed in service as a demonstrator or company vehicle, whichever is earlier.

To obtain service under this warranty, the vehicle must be brought, upon failure of a Smog Check test or upon discovery of the defect, to the workshop of any authorized BMW center, during normal business hours. The BMW center will honor or deny your claim within 30 days. If the claim is denied, the BMW center will notify you in writing of the reason(s). The BMW center is required by law to honor the claim if notice is not given to the owner within 30 days.

The BMW center will, without charge for parts or labor (including diagnosis), either adjust, repair or replace the defective part and other parts affected by the failure of the warranted

part, if any. If your vehicle failed the California Smog Check test or an EPA approved short test, then BMW NA will repair your vehicle so that it will pass this test. Items that require scheduled replacement are warranted up to the replacement interval specified in the Service section of this Statement. BMW NA may repair a part in lieu of replacing it when performing warranty repairs. Parts for which replacements are made become the property of BMW NA. After 3 years or 50,000 miles, and in accordance with paragraph (c) above, such repairs are limited to the repair or replacement of those parts identified in the California Emissions Warranty List.

If your California registered vehicle is between 7 and 8 years old and has been driven less than 80,000 miles, then your vehicle is eligible for additional warranty coverage under the Federal Emissions Warranty.

A repair performed as the result of a smog check test failure due to a defect in a part, which is warranted for 7 years/70,000 miles, is covered.

In all cases, a reasonable time, not to exceed 30 days, must be allowed for a warranty repair to be completed, after the car is received by the BMW center.

It is the owner's responsibility to have all required maintenance services performed (at the owner's expense), as prescribed in the maintenance schedule for the BMW Emission Control System. Service intervals are computed by the service interval indicator and displayed on the instrument panel.

*The California Emissions Control System Limited Warranty applies to all 2005 U.S. specification BMW vehicles sold, leased, and/or registered in California, Maine, Massachusetts, New York or Vermont.

However, BMW NA will not deny your warranty repair claims solely because you do not have maintenance records or you did not perform the required maintenance unless BMW NA

demonstrates that such lack of required maintenance is a direct cause of the emission control system failure. The instructions for required maintenance and use can be found in the Owner's Manual and in the Service section of this Statement.

It is strongly recommended that any replacement parts used for maintenance, repair or replacement of emission control systems be genuine BMW Service Parts or BMW Authorized Remanufactured Parts. Without invalidating this warranty, the owner may elect to have maintenance, repair or replacement of the emission control systems performed by any automotive repair establishment, or elect to use parts other than BMW Authorized Remanufactured or genuine BMW Service Parts. However, the cost of such service or parts will not be covered under this warranty, except in emergency situations. In an emergency situation, where an authorized BMW center is not reasonably available or a warranty replacement part is not available within 30 days, repairs may be performed at any available service establishment or by any individual using any replacement part.

A repair not completed within 30 days constitutes an emergency. BMW NA will reimburse the owner for such emergency repairs (including labor, parts and diagnosis not to exceed BMW suggested retail price for all warranted parts replaced and labor charges based on the manufacturer's recommended time allowance for the warranty repair and the geographically appropriate hourly labor rate) that are covered under this warranty. Replaced parts and paid invoices must be presented to a BMW center as a condition of reimbursement for emergency repairs not performed by a BMW center.

The use of replacement parts, which are not of equivalent quality, may impair the effectiveness of emission control systems. If other than genuine BMW Service Parts or Authorized Remanufactured Parts are used for maintenance, repair or replacement of components affecting emission control, the owner should obtain assurances that such parts are war-

ranted by their manufacturer to be equivalent to genuine BMW parts in performance and durability. BMW NA assumes no liability under this warranty with respect to parts other than genuine BMW parts.

However, the use of non-BMW replacement parts does not invalidate the warranty on other components, unless non-BMW parts cause damage to warranted parts.

What is not covered

This warranty does not cover malfunctions caused by any of the following: accident, flood, misuse, modification, alteration, tampering, disconnection, improper or inadequate maintenance, except if performed by an authorized BMW center doing warranty repair work, use of leaded fuel or fuel other than as specified in the Owner's Manual.

The replacement of maintenance parts, such as spark plugs, filters and similar items used in required maintenance services or the repair or replacement of maintenance parts beyond the first replacement interval.

Any car on which the odometer has been replaced or altered and the true mileage cannot be determined.

The car, if the vehicle identification number is altered or cannot be determined, or if the car has been declared a total loss or sold for salvage purposes.

General

The warranty gives you specific legal rights, and you may also have other rights which vary from state to state.

THE DURATION OF ANY IMPLIED WARRANTIES, INCLUDING THE IMPLIED WARRANTY OF MERCHANTABILITY, IS LIMITED TO THE DURATION OF THE EXPRESS WARRANTIES HEREIN. BMW OF NORTH AMERICA HEREBY EXCLUDES INCIDENTAL AND CONSEQUENTIAL DAMAGES, INCLUDING LOSS OF TIME, INCONVENIENCE, OR LOSS OF USE OF THE VEHICLE, FOR ANY BREACH OF ANY

EXPRESS OR IMPLIED WARRANTY, INCLUDING THE IMPLIED WARRANTY OF MERCHANTABILITY, APPLICABLE TO THIS PRODUCT.

For assistance in determining which parts are covered by this warranty, please contact your authorized BMW center or the BMW NA Customer Relations Department at 1-800-831-1117 or through our website at www.bmwusa.com. You may obtain further information concerning the emissions warranty or report violations of warranty terms, by contacting Air Resources Board (ARB), Mobile Source Division, 9528 Telstar Avenue, El Monte, CA 91731. Please include the title of the BMW service department head and telephone number.

California Emission Warranty Parts List

The following components are covered for defects by the California Emission Control System Limited Warranty for a period of 7 years or 70,000 miles, whichever comes first.

COMPONENT	3 Series
INTAKE MANIFOLD	•
INTAKE MANIFOLD GASKET	•
VANOS CAMSHAFT POSITION CONTROLLER	•
ENGINE CONTROL MODULE	•
FUEL TANK	•
EXHAUST MANIFOLD	•
EXHAUST MANIFOLD GASKET	•
EXHAUST MANIFOLD WITH CATALYST	•
THREE WAY CATALYTIC CONVERTER	•
TRANSMISSION CONTROL MODULE	•
SMG CONTROL MODULE	•
KNOCK SENSOR	•

Notice

The "National Traffic & Motor Vehicle Safety Act of 1966" requires manufacturers to be in a position to contact the vehicle owners when a correction of a product defect becomes necessary. Please fill in the attached postcard if you change your address or purchase a used BMW.

Tire Warranty Statement

Tires are warranted by their respective manufacturer as detailed in the applicable tire manufacturer's warranty statements. Instructions for proper tire care and maintenance are contained in the Owner's Manual. Should you experience difficulty in obtaining warranty service from a tire manufacturer, your authorized BMW center will assist you in resolving the difficulty.

Notes

Notes

Notes

Notes

Notes



NO POSTAGE
NECESSARY
IF MAILED IN
THE
UNITED STATES

BUSINESS REPLY MAIL
FIRST CLASS MAIL PERMIT NO. 131 WESTWOOD, NJ



BMW of North America, LLC
P.O. Box 1227
Westwood, NJ 07675-9868

Attn: Customer Satisfaction



NO POSTAGE
NECESSARY
IF MAILED IN
THE
UNITED STATES

BUSINESS REPLY MAIL
FIRST CLASS MAIL PERMIT NO. 131 WESTWOOD, NJ

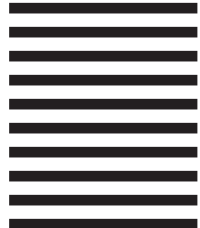

BMW of North America, LLC
P.O. Box 1227
Westwood, NJ 07675-9868

Attn: Customer Satisfaction



Please Check One

ADDRESS CHANGE

USED CAR PURCHASE

Month Day Year

Grid for date input (Month, Day, Year)

Date

Model input box

Model

Chassis Number input box

Chassis Number

(the last eight digits of the VIN)

Last Name and First Name input boxes

Last Name

First Name

Number and Street input boxes

Number

Street

Apt./Suite input box

Apt./Suite

City and State input boxes

City

State

Zip Code input box

Zip Code

Telephone input box (AM)

AM

Telephone

Telephone input box (PM)

PM

Telephone

Fax input box (AM)

AM

Fax

Fax input box (PM)

PM

Fax

Email input box

Email

Please Check One

ADDRESS CHANGE

USED CAR PURCHASE

Month Day Year

Grid for date input (Month, Day, Year)

Date

Model input box

Model

Chassis Number input box

Chassis Number

(the last eight digits of the VIN)

Last Name and First Name input boxes

Last Name

First Name

Number and Street input boxes

Number

Street

Apt./Suite input box

Apt./Suite

City and State input boxes

City

State

Zip Code input box

Zip Code

Telephone input box (AM)

AM

Telephone

Telephone input box (PM)

PM

Telephone

Fax input box (AM)

AM

Fax

Fax input box (PM)

PM

Fax

Email input box

Email

